

Digital NTP PoE Clocks-GTD368 Series



Time Synchronization by NTP

Powered by PoE (Power over Ethernet)

NTP Introduction

Network Time Protocol (NTP) is a networking protocol for clock synchronization between computer systems over packet-switched, variable-latency data networks. NTP is the most popular time synchronization protocol in current use.

NTP is intended to synchronize all participating computers to within a few milliseconds of Coordinated Universal Time(UTC). It uses the intersection algorithm, a modified version of Marzullo's algorithm, to select accurate time servers and is designed to mitigate the effects of variable network latency. NTP can usually maintain time to within tens of milliseconds over the public Internet, and can achieve better than one millisecond accuracy in local area networks under ideal conditions. Asymmetric routes and network congestion can cause errors of 100 ms or more.

The Power over Ethernet Advantages

PoE is a network standard based on IEEE 802.3af that delivers DC power and data to Ethernet connected devices. PoE is fully compatible with powered and non-powered 10/100BaseT Ethernet devices.

PoE clocks utilize Power over Ethernet (PoE), the same technology that powers IP phones. The PoE clock receives its power and data from a standard CAT5 patch cable via a PoE injector or switch. By simply using a Windows-based application, the user can view and/or change existing configuration of the entire system. The clock will receive its time from a SNTP time server for accurate timekeeping, thus eliminating the need of a master clock.

Technical Specifications

General

Digit Size:	4 Inch
Viewing Distance:	150+ feet (50+ meters)
Accuracy:	+/- approximately 20 milliseconds
Mounting Options:	Surface, Pendant, Cantilever, Double-sided
Time Format:	12 or 24 hour display



Synchronized Time Systems

LED Color: Red, Green, Yellow, Amber

Network

Signal Input: (S)NTP via RJ45 Connector
Data Protocols: NTP, SNTP
Routing Protocols: IPv4
Compatibility: Ethernet version 2/IEEE802.3af
Ethernet: Supports 10/100 BASE-T (RJ45) connections
IP Address Assignment: Static IP address or dynamic (DHCP)
Additional Info: Supports DNS
Device Management: Software

Power Supply

Input Voltage: PoE (IEEE 802.3 af), less than 13 Watt
or 12V DC for red/yellow/amber clocks, 18V DC for green clocks

Environmental

Operating Temperature: -10°C to 60°C
Operating Humidity: 90% maximum, non-condensing

Housing

Case Material: Reinforced Acrylonitrile Butadiene (ABS), metal, stainless steel (SS304)
Case Color: ABS in black, metal in black or white, stainless steel in grey
Dimensions: For 4 digit clock:
30.2cm*15.7cm*5.7cm (single-sided);
30.2cm*15.7cm*8cm (double-sided)
For 6 digit clock:
43cm*15.7cm*5.7cm (single-sided);
43cm*15.7cm*8cm (double-sided)
Weight: For 4 digit clock: 0.7kg (single-sided); 1.2kg (double-sided)
For 6 digit clock: 0.9kg (single-sided); 1.5kg (double-sided)

Compliance: CE, FCC, RoHS, ISO

Features

- Available with 4" digits, 4 digit display or 6 digit display
- Red display standard; Optional White, Blue, Green, Amber, Yellow displays
- Time is automatically set by Simple Network Time Protocol(SNTP)- no master clock or serial connection required
- Uses PoE (Power over Ethernet) for easy installation and operation
- Static IP or DHCP addressing

Synchronized Time Systems

- 12 or 24 hour display
- Automatic Daylight Saving Time change (if applicable)
- Adjustable brightness (brilliant, bright, normal, dim, off)
- Capability to receive realtime countdown command
- If connection to NTP server is lost the clocks will continue to run on the built-in time base. When the connection is restored it will synchronize automatically.
- The clock features time loss notification by having a light on on the right lower corner
- Can be single sided (has one display) or double sided (has two displays)



Single-sided



Double-sided



Double-sided



Ceiling Mounting



Wall Mounting

Optional

Capable of interface with:

- (1) Temperature or humidity sensor

We can add a sensor to the clock then it can display time, temperature, humidity alternately:

The clock can display time, temperature, humidity alternately:



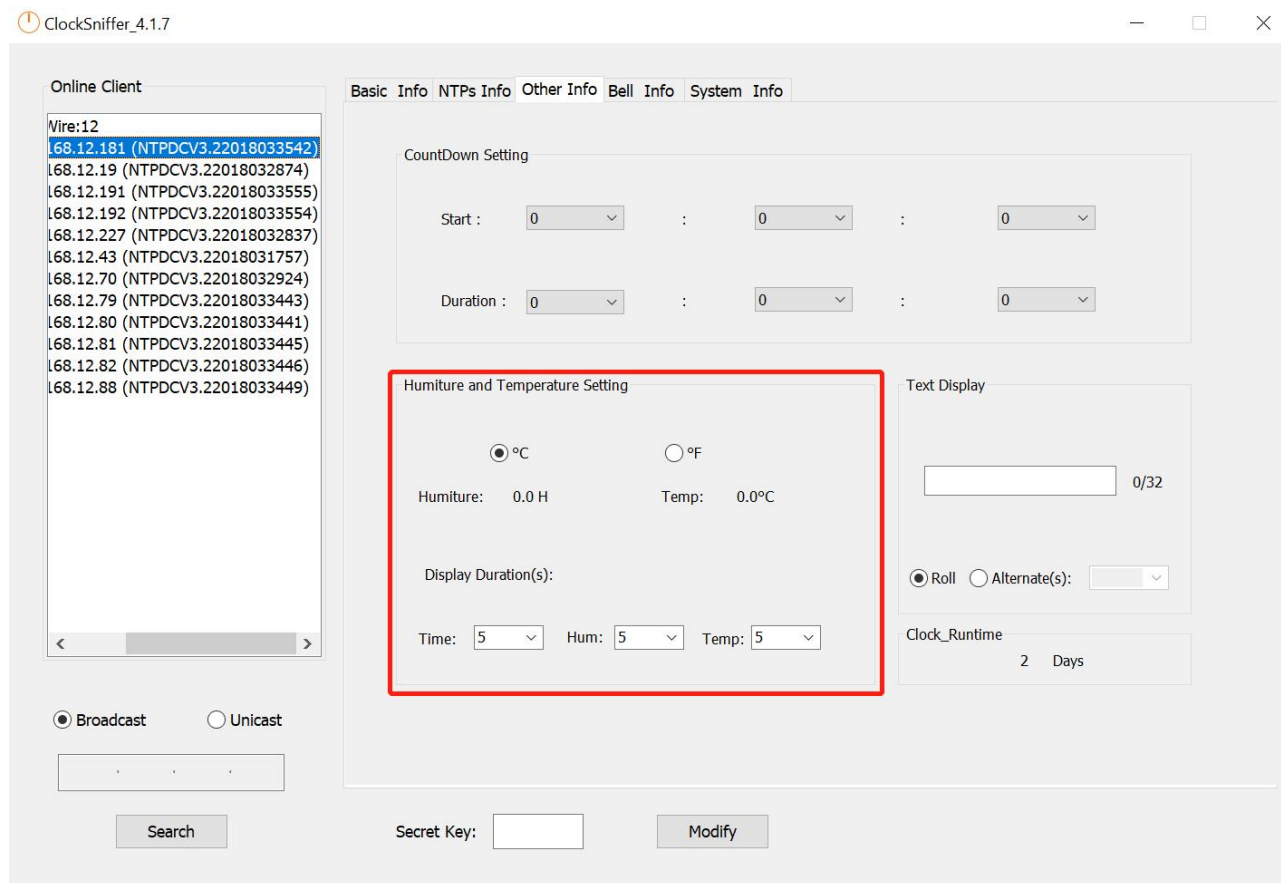

Humiture and Temperature Setting by Software

(2) Built-in bell relay

We can add a built-in bell relay to the clock. Then the clock can be connected to a bell. The bell can be programmed to ring at 30 different moments using the management software.

The voltage and current of the bell should be $\cong 5A\ 30VDC$, or $\cong 5A\ 250VAC$.

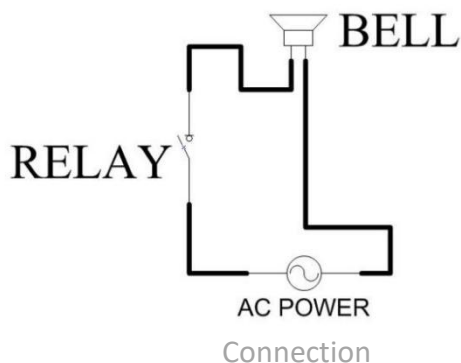

The screenshot shows the 'Bell Info' tab of the software. On the left, there is a list of IP addresses under 'Online Client', with '168.12.181 (NTPDCV3.22018033542)' selected. Below this list are radio buttons for 'Broadcast' (selected) and 'Unicast', and a 'Search' button. The main area is a table for configuring 10 events. Each event row includes a checkbox, a start time (HH:MM:SS), and checkboxes for days of the week (Sun-Sat). A 'Clean' button is located below the table. At the bottom, there is a 'Secret Key' input field and a 'Modify' button.

Event	Start Time	Days	Durations(s)
<input type="checkbox"/> 1	0 : 0 : 0	<input type="checkbox"/> Sun <input type="checkbox"/> Mon <input type="checkbox"/> Tue <input type="checkbox"/> Wed <input type="checkbox"/> Thu <input type="checkbox"/> Fri <input type="checkbox"/> Sat	▼
<input type="checkbox"/> 2	0 : 0 : 0	<input type="checkbox"/> Sun <input type="checkbox"/> Mon <input type="checkbox"/> Tue <input type="checkbox"/> Wed <input type="checkbox"/> Thu <input type="checkbox"/> Fri <input type="checkbox"/> Sat	▼
<input type="checkbox"/> 3	0 : 0 : 0	<input type="checkbox"/> Sun <input type="checkbox"/> Mon <input type="checkbox"/> Tue <input type="checkbox"/> Wed <input type="checkbox"/> Thu <input type="checkbox"/> Fri <input type="checkbox"/> Sat	▼
<input type="checkbox"/> 4	0 : 0 : 0	<input type="checkbox"/> Sun <input type="checkbox"/> Mon <input type="checkbox"/> Tue <input type="checkbox"/> Wed <input type="checkbox"/> Thu <input type="checkbox"/> Fri <input type="checkbox"/> Sat	▼
<input type="checkbox"/> 5	0 : 0 : 0	<input type="checkbox"/> Sun <input type="checkbox"/> Mon <input type="checkbox"/> Tue <input type="checkbox"/> Wed <input type="checkbox"/> Thu <input type="checkbox"/> Fri <input type="checkbox"/> Sat	▼
<input type="checkbox"/> 6	0 : 0 : 0	<input type="checkbox"/> Sun <input type="checkbox"/> Mon <input type="checkbox"/> Tue <input type="checkbox"/> Wed <input type="checkbox"/> Thu <input type="checkbox"/> Fri <input type="checkbox"/> Sat	▼
<input type="checkbox"/> 7	0 : 0 : 0	<input type="checkbox"/> Sun <input type="checkbox"/> Mon <input type="checkbox"/> Tue <input type="checkbox"/> Wed <input type="checkbox"/> Thu <input type="checkbox"/> Fri <input type="checkbox"/> Sat	▼
<input type="checkbox"/> 8	0 : 0 : 0	<input type="checkbox"/> Sun <input type="checkbox"/> Mon <input type="checkbox"/> Tue <input type="checkbox"/> Wed <input type="checkbox"/> Thu <input type="checkbox"/> Fri <input type="checkbox"/> Sat	▼
<input type="checkbox"/> 9	0 : 0 : 0	<input type="checkbox"/> Sun <input type="checkbox"/> Mon <input type="checkbox"/> Tue <input type="checkbox"/> Wed <input type="checkbox"/> Thu <input type="checkbox"/> Fri <input type="checkbox"/> Sat	▼
<input type="checkbox"/> 10	0 : 0 : 0	<input type="checkbox"/> Sun <input type="checkbox"/> Mon <input type="checkbox"/> Tue <input type="checkbox"/> Wed <input type="checkbox"/> Thu <input type="checkbox"/> Fri <input type="checkbox"/> Sat	▼

Bell Configuration by Software

We reserve the right to make changes at any time.